



GREENLINE SAFETY STAIRS

Bridge the Gap Between Safety and Liability

Greenline Safety Stairs are specifically designed for various industries and applications that require accessing the top of a vehicle. The safety stair is designed for applications where the working range exceeds angles greater than 15° above or below the platform height. The **Greenline** Safety Stair provides a solution for various applications where access is a problem.

Greenline Safety Stairs provide safe access from the loading rack or dock to an elevated walkway during a loading/unloading process. Our Safety Stairs are designed with non-skid self-leveling grip strut treads.

Greenline Safety Stairs can be manufactured from carbon steel, aluminum, and fiberglass (or a combination of each). Benko Products, Inc. can design a Safety Stair to meet any application that your operation would require.

Maneuvering the Safety Stair is performed by hand. Simple and compact tension spring balance method makes all movements easy. A slight push or pull positions the stair for safe access to the vehicle. Each unit is equipped with a locking mechanism for storage in the vertical position.



BENKO PRODUCTS INC.

5350 Evergreen Parkway,
Sheffield Village, OH 44054
(440) 934-2180
Fax (440) 934-4052
www.benkoproducts.com
Email: dingram@green-mfg.com



*New
Telescoping
Midrail*

SS400 Series Aluminum Safety Stairs

Combine these features with several advantages listed below to make **Greenline** your choice.

- Folding tubular handrails with telescoping midrails on each side of the stair for increased operator safety and compliance with OSHA standards as we interpret them for 200 lbs. directional force. Hassle-free installation of midrail.
- Neoprene bumpers to eliminate damage to the vehicles being serviced.
- Main axles are equipped with self aligning permanently lubed bearings. The self-leveling tread axles on aluminum models have bronze bushings for low maintenance.

nance.

- A variety of finishes are available: standard safety yellow enamel, hot dipped galvanized, uncoated or anodizing for aluminum models.
- Optional side mount brackets make side mounting to your existing structure easy.
- Optional welded stops prevent the stair from traveling beyond a predetermined position.
- Larger models may require the use of a manual or electrically operated hydraulic lift package.
- Tension springs are enclosed in the side panels to prevent pinch points and corrosion to the springs.



GREENLINE WORKING RANGE CHART

200 & 400 Series Safety Stairs

Range when Top Mounted

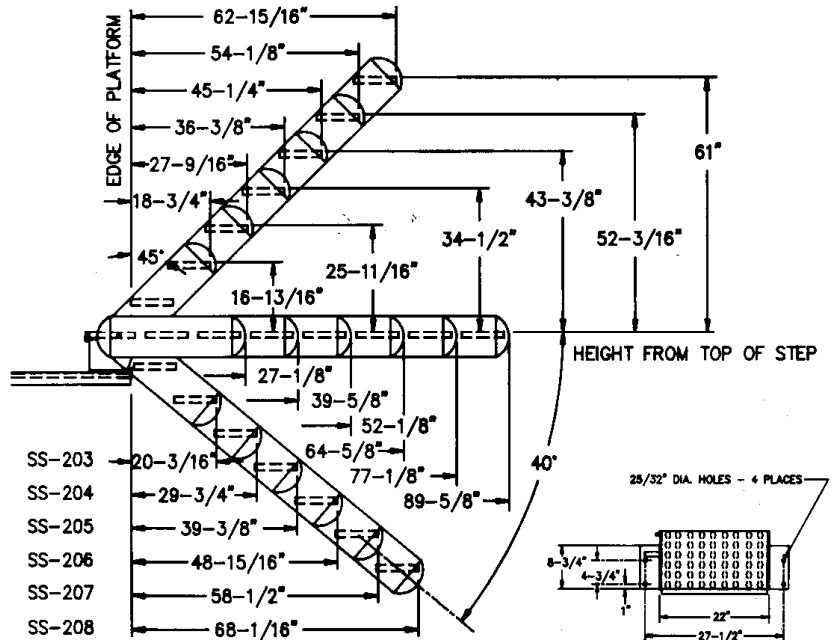

Range when Side Mounted

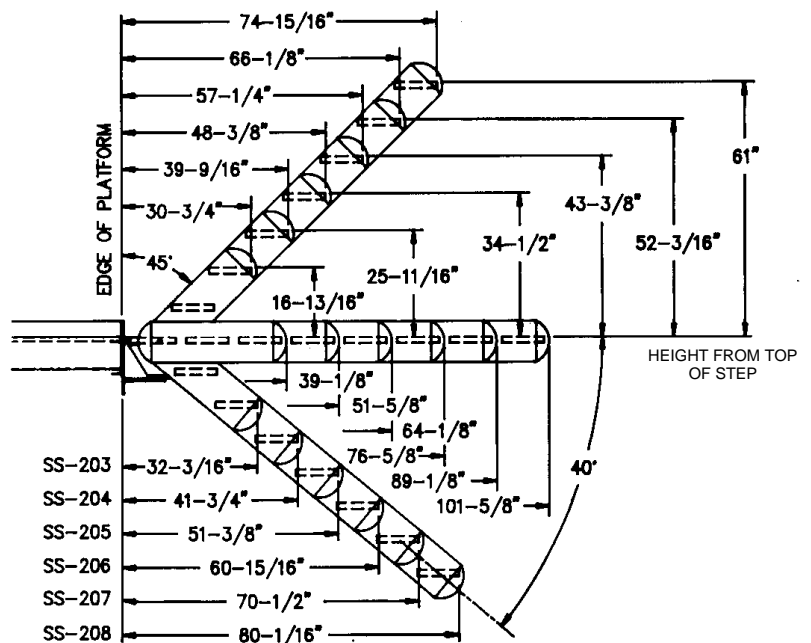

BENKO PRODUCTS INC.

5350 Evergreen Parkway,
 Sheffield Village, OH 44054
 (440) 934-2180 Fax (440) 934-4052
 www.benkoproducts.com
 Email: dingram@green-mfg.com



GREENLINE SAFETY STAIRS

Bridge the Gap Between Safety and Liability

Steel Safety Stairs

The **Greenline** SS200 series Safety Stairs are designed for various applications where the working range exceeds angles greater than 15° above or below the platform height. The Safety Stair has capabilities of providing access to vehicles requiring the unit to travel as low as 40° below the platform height.

The self-leveling non-skid grip strut treads provide the operators a level surface during any angle of usage. Each model can be equipped with an optional self-leveling hoop and can be flush mounted off the side of the platform with side mount brackets. Some larger models may require manual or electrically operated hydraulic lift packages for operator ease.

Aluminum Safety Stairs

New Stronger Design

The **Greenline** SS400 series Safety Stairs are light weight aluminum construction with galvanized steel back box sections and back uprights. This offers low maintenance and excellent weathering characteristics. This model provides access to vehicles where the working range exceeds angles greater than 15° above or below the platform height. The Safety Stair has capabilities of providing access to vehicles requiring the unit to travel to 40° below the platform height.

The self-leveling non-skid grip strut treads are designed with bronze bushings to provide minimal maintenance. Each model can be equipped with an optional self-leveling hoop and can be flush mounted off the side of the platform with side mount brackets. Some larger models may require manual or electrically operated hydraulic lift packages for operator ease.

Greenline series SS200 and SS400 Safety Stairs are available in 3, 4, 5, 6, 7 & 8 tread models. Standard models have a tread width of 22", with various customized widths available to fit the application.

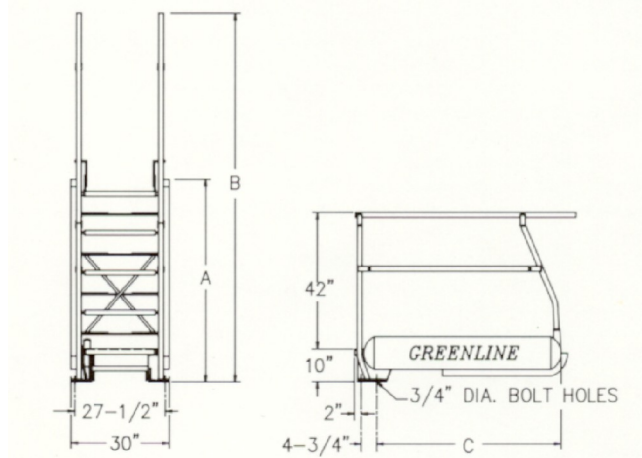

Typical SS200 Series Dimensions*						
Model	A		B		C	
	in.	mm	in.	mm	in.	mm
SS203	39	901	90	2286	31 3/8	797
SS204	51 1/2	1308	102 1/2	2604	43 7/8	1114
SS205	64	1626	115	2921	56 3/8	1432
SS206	76 1/2	1943	127 1/2	3239	68 7/8	1749
SS207	89	2261	140	3556	81 3/8	2067
SS208	101 1/2	2578	152 1/2	3874	93 7/8	2384

* Custom dimensions available

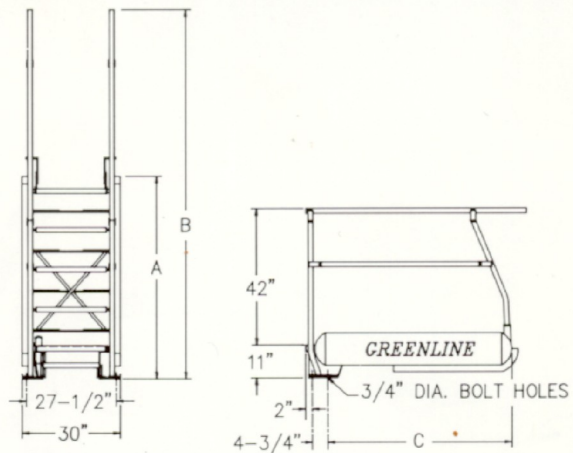

Typical SS400 Series Dimensions*						
Model	A		B		C	
	in.	mm	in.	mm	in.	mm
SS403	39 3/4	1010	90	2286	31 3/8	797
SS404	52 1/4	1327	102 1/2	2604	43 7/8	1114
SS405	64 3/4	1645	115	2921	56 3/8	1432
SS406	77 1/4	1962	127 1/2	3239	68 7/8	1749
SS407	89 3/4	2280	140	3556	81 3/8	2067
SS408	102 1/4	2597	152 1/8	3870	93 7/8	2384

* Custom dimensions available